



Video Optic Cine Audio Systems

The Vocas MB-450.

In addition to the current line of matteboxes, Vocas proudly presents the most exciting advance in image control and light management for EFP/HD/film cameras, packed with features that protect your camera and enhance your creativity.

Specifications:

- For use with up to 5 filters (2 fully rotatable).
- Made to fit the new filter standard 5,65"X5,65" or smaller.
- Fits on large diameter lenses (up to 144mm.)
- Optional patented Tilt Shift filter unit.
- New designed and patented flag fixation.
- Externally operated Eyebrows.
- Exchangeable matte system.
- Swing Away bracket will be available shortly.
- The basic unit can be used as Clip-on or on rails support.
- Availability: November 2006.

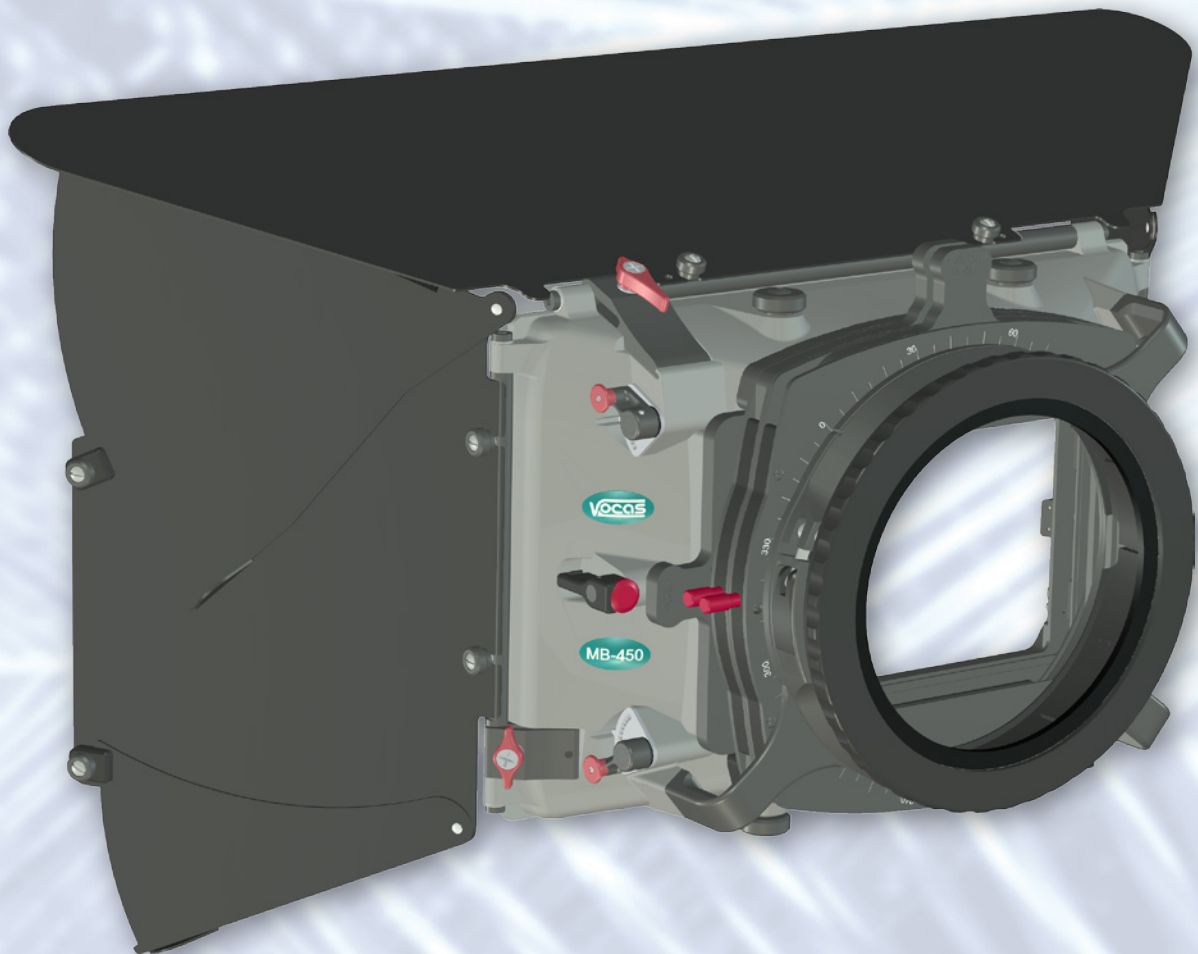

WWW.VOCAS.COM

PO Box 191, 1200 AD, Hilversum, Nederland
Tel.: +31(0)35-6233707, Fax: +31(0)35-6233997
e-mail: info@vocas.com, Web: www.vocas.com

Ultimate light management